

# B4250

## Machine Specifications:

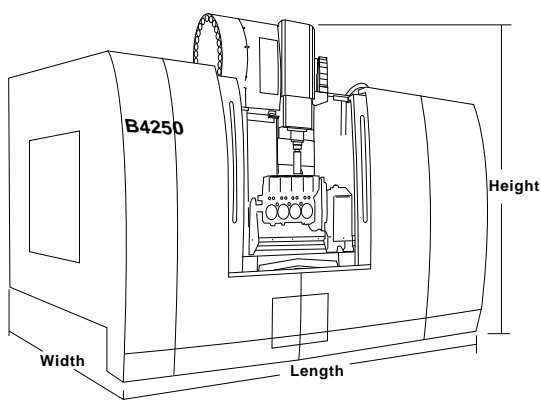

Table Size:	20" x 49.5" (508mm x 1257mm)	23.6" x 66.9" (600mm x 1700mm)
Longitudinal travel (X):	42" (1067mm)	58" (1473mm)
Cross travel (Y):	24" (607mm)	26" (660mm)
Vertical travel (Z):	34" (864mm)	36" (914mm)
A axis:	360 degree rotation	360 degree rotation
Maximum table load:	2200lbs (1000kg)	2200lbs (1000kg)
Spindle power:	15HP/ 11kW	20HP/ 15kW
Spindle taper:	CAT40	CAT40
Spindle speed:	8,000 RPM	10,000 RPM
ATC	24 Position Swing Arm tool changer	24 Position Swing Arm tool changer
Rapid feed rates (X,Y,Z):	X,Y 1000 IPM, Z 800 IPM	X,Y 1000 IPM, Z 800 IPM
Accuracy:	0.0005" (0.0127mm)	0.0005" (0.0127mm)
Repeatability:	0.0002" (0.0060mm)	0.0002" (0.0060mm)
Axis drive motors (X,Y,Z,A):	X,Y 2.9kW, Z 4.5kW, A 1kW AC Brushless	X,Y 2.9kW, Z 4.5kW, A 1kW AC Brushless
Enclosure	Full Enclosure with Chip Auger	Full Enclosure with Chip Auger
Axis way design	Heavy Duty Linear guideways	Heavy Duty Linear guideways
Coolant pump:	45 PSI, 12 gal/min, 50 Gallon Capacity	45 PSI, 12 gal/min, 110 Gallon Capacity
Auto lubrication pump:	150W .13 liters/min	150W .13 liters/min
Coolant separator	Disc type Oil/Coolant separator	Disc type Oil/Coolant separator
Way Covers	Telescoping metal way covers	Telescoping metal way covers
Power requirement:	43kVA, 50-60Hz, 208-240v, 3 Phase, 100 amps	43kVA, 50-60Hz, 208-240v, 3 Phase, 100 amps
Air requirement:	90-100 PSI, 6.2-6.8 Bar	90-100 PSI, 6.2-6.8 Bar



Machine Footprint:	B4250	B4250 XL
Length:	121" (3073 mm)	179" (4546 mm)
Width:	97" (2463 mm)	89" (2260 mm)
Max Height:	116" (2946 mm)	126" (3200 mm)
Shipping Footprint:		
Length:	121" (3073 mm)	163" (4115 mm)
Width:	97" (2463 mm)	90" (2286 mm)
Height:	109" (2768 mm)	112" (2845 mm)
Weight:		
Machine:	14,000 lbs (6350 Kg)	16,000 lbs (7273 Kg)

## Full Service Training and Warranty:

- Customized one-on-one training, tailored to each customer's specific needs.
- One year standard warranty on parts, labor, and technical support. Machine in-shop setup included.
- Personalized service and support. Support available outside M-F 9-5
- Internet enabled for remote training and trouble shooting
- Factory remote support, Remote diagnostics, Skype video and instant messaging
- One number to call for every component in the system. Direct support phone numbers.

